



INSTALLATION AND OPERATION MANUAL

B-Vent Gas Fireplace Insert

MERIT™ SERIES

Retain These Instructions For Future Reference

P/N 775,225M Rev. A, 06/2007

A French manual is available upon request. Order P/N 775,225CF.
Ce manuel d'installation est disponible en français, simplement
en faire la demande. Numéro de la pièce 775,225CF.

In the Commonwealth of Massachusetts:

- Installation must be performed by a licensed plumber or gas fitter
- See Table of Contents for location of additional Commonwealth of Massachusetts requirements

Tested &
Listed By  Beaverton
Oregon USA
OMNI-Test Laboratories, Inc.
Report No. 050-S-07b-5



Firestar™ (GC3)



! WARNINGS



- **Hot! Do not touch! The glass and surfaces of this appliance will be hot during operation and will retain heat for a while after shutting off the appliance. Severe burns may result.**
- **Carefully supervise children in the same room as appliance.**
- **Suitable for installation into masonry or factory built fireplaces. These appliances may be installed in an after-market permanently located, manufactured (mobile) home, where not prohibited by local codes. This appliance is only for use with the type of gas indicated on the rating plate. This appliance is not convertible for use with other gases unless a certified kit is used.**
- **Lennox™ gas-burning appliances are designed for use as a supplemental heater. They are not intended for continuous use as a primary heat source.**

WARNING: If the information in this manual is not followed exactly, a fire or explosion may result causing property damage, personal injury or loss of life.

FOR YOUR SAFETY

Do not store or use gasoline or other flammable vapors or liquids in the vicinity of this or any other appliance.

WHAT TO DO IF YOU SMELL GAS:

- **DO NOT** light any appliance.
- **DO NOT** touch any electrical switches.
- **DO NOT** use any phone in your building.
- **Immediately call your gas supplier from a neighbor's phone. Follow your gas supplier's instructions.**
- **If your gas supplier cannot be reached, call the fire department.**

Installation and service must be performed by a qualified installer, service agency or the gas supplier.

AVERTISSEMENT: Assurez-vous de bien suivre les instructions données dans cette notice pour réduire au minimum le risque d'incendie ou d'explosion ou pour éviter tout dommage matériel, toute blessure ou la mort.

POUR VOTRE SÉCURITÉ: Ne pas entreposer ni utiliser d'essence ni d'autres vapeurs ou liquides inflammables à proximité de cet appareil ou de tout autre appareil.

POUR VOTRE SÉCURITÉ: Que faire si vous sentez une odeur de gaz:

- **Ne pas tenter d'allumer d'appareil.**
- **Ne touchez à aucun interrupteur.**
- **Ne pas vous servir des téléphones se trouvant dans le bâtiment**
- **Appelez immédiatement votre fournisseur de gaz depuis un voisin. Suivez les instructions du fournisseur.**
- **Si vous ne pouvez rejoindre le fournisseur de gaz, appelez le service des incendies.**

L'installation et l'entretien doivent être assurés par un installateur ou un service d'entretien qualifié ou par le fournisseur de gaz.

Table of Contents

CAUTIONS & SAFETY	3
ORIFICE SIZE / ALTITUDE ADJUSTMENT	4
FIREPLACE REQUIREMENTS	4
CODES & APPROVALS	4
REQUIREMENTS FOR THE COMMONWEALTH OF MASSACHUSETTS	4
PRE-INSTALLATION	5-7
FEATURES	5
PACKAGING LIST	5
RATINGS	5
INSERT & FIREPLACE DIMENSIONS	6
CLEARANCES TO COMBUSTIBLES	7
INSERT LEVELING	7
INSTALLATION	8-12
VENTING INSTALLATION	8
FLUE COLLAR CONNECTION	8
ZERO CLEARANCE FIREPLACE INSTALLATION	9
BRICK LINER INSTALLATION	9
LOG INSTALLATION	9
SURROUND PANELS INSTALLATION	10
LOWER FRONT FILLER PANEL	11
GAS LINE INSTALLATION	11
GAS PRESSURE REQUIREMENTS	11
GAS SUPPLY LINE SIZING	11
LP & NATURAL GAS SUPPLIES	12
AIR SHUTTER ADJUSTMENT	12
OPERATING INSTRUCTIONS	13-16
PRE-LIGHTING CHECKLIST	13
LIGHTING INSTRUCTIONS	13
FLAME COLOR & BEHAVIOR	14
REPLACING BURNER ORIFICES	14
PAINT CURING	15
QUIET OPERATION	15
BLOWER	15
“ON-OFF” SWITCH AND THERMOSTAT	15
PILOT ADJUSTMENT	15
MILLIVOLT CONTROL SYSTEM	16
MAINTENANCE & SERVICING	17-19
MAINTENANCE CHECKLIST	17
GLASS MAINTENANCE	17
GLASS DOOR REMOVAL	17
GLASS DOOR CLEANING AND REPAIR	18
BLOWER WIRING DIAGRAM	18
BLOWER REMOVAL	18
ELECTRICAL REQUIREMENTS	18
FUEL CONVERSION & CASSETTE INSTALLATION	19
TROUBLESHOOTING	20
REPLACEMENT PARTS	21
INSERT LABELS	22-23
PRODUCT REFERENCE INFORMATION	24



CAUTIONS & SAFETY

- ◆ **FOR YOUR SAFETY** do not install or operate your Firestar™ gas insert without first reading & understanding this manual. Any installation or operation of the appliance deviating from that which is stated in this manual **WILL** void the warranty & may be hazardous.
- ◆ **INSTALLATION & REPAIR SHOULD ONLY BE DONE BY A QUALIFIED SERVICE TECHNICIAN. DO NOT ATTEMPT TO SERVICE THE APPLIANCE YOURSELF.**
- ◆ The insert should be inspected & cleaned before use & at least annually by a qualified service technician. More frequent cleaning may be required due to excessive lint from bedding material, carpeting, etc.
- ◆ It is imperative that control compartments, burners, & circulating air passageways of the room heater be kept clean.
- ◆ Adequate clearances around the combustion chamber and accessibility clearances for servicing & proper operation must be maintained.
- ◆ Turn off the gas before servicing this appliance. It is recommended that a qualified service technician perform an appliance check-up at the beginning of each heating season.
- ◆ All installations must conform with all local, state, & national codes. In the absence of local codes, the installation must conform with National Fuel Gas Code ANSI Z223.1-latest edition, also known as NFPA 54. Refer to the National Fuel Gas Code & local zoning & code authorities for details on installation requirements. Your Firestar gas insert must be vented to the outside in accordance with the latest edition of the National Fuel Gas Code.
- ◆ This gas insert **MUST** be vented directly to the outside & **MUST NEVER** be attached to a chimney serving a separate solid fuel burning appliance. Each gas appliance **MUST USE** a separate vent system. Common vent systems are **PROHIBITED**.
- ◆ This appliance uses room air for combustion. It is imperative that provisions for adequate combustion and ventilation air be made. This appliance is **NOT** designed to and will not operate in a negative pressure. Contact your dealer if you suspect such a situation exists.
- ◆ Mobile home installations must conform with the Mobile Home Construction and Safety Standard, Title 24 CFR, Part 3280, or, when such a standard is not applicable, the Standard for Mobile Home Installations, ANSI A225.1 - latest edition.
- ◆ The appliance, when installed, must be electrically grounded in accordance with local codes or in the absence of local codes, with the National Electrical Code, ANSI/NFPA 70 - latest edition.
- ◆ Your Lennox™ gas insert must be equipped for the proper fuel type & altitude at which it will be operated. Any operation outside the parameters outlined in this manual may result in a hazardous condition & will void the warranty. Please carefully read the sections pertaining to these subjects and/or be sure your appliance is properly equipped.
- ◆ Do not use this insert if any part has been under water. Immediately call a qualified service technician to inspect the appliance & to replace any part of the control system & any gas control which has been under water.
- ◆ Due to high temperatures, the insert should be located out of traffic areas & away from furniture & draperies.
- ◆ Children & adults should be alerted to the hazards of high surface temperature & should stay away to avoid burns or clothing ignition. Young children should be carefully supervised when they are in the same room as the Lennox gas insert. Clothing or any other flammable material should not be placed on or near the insert.
- ◆ Never use solid fuels such as wood, paper, cardboard, coal, or any flammable liquids, etc., in this appliance.
- ◆ Any grill, panel, or glass removed for service **MUST** be replaced prior to operating the insert. Do not operate appliance with the glass front removed, cracked or broken. Replacement of the glass should be done by a qualified service technician.
- ◆ **DO NOT USE** abrasive cleaner on the glass door assembly. **DO NOT ATTEMPT** to clean the glass door when it is hot.
- ◆ Gold & nickel plated surfaces must be cleaned with glass cleaner & a clean soft cloth before firing the first time or fingerprints will remain permanently. **NEVER** use brass polish to clean gold or nickel, this will remove the plating!!!
- ◆ When opening the lower door on the face while the insert is burning, pull at the far left or far right vent openings, because the door is hot during operation.
- ◆ Lennox Hearth Products, its employees, or any of its representatives assume no responsibility for any damages caused by an inoperable, inadequate, or unsafe condition as a result of any improper operation, service or installation procedures, whether direct or indirect.
- ◆ **INSTALLER: THESE INSTRUCTIONS ARE TO REMAIN WITH THE HOME OWNER!**

Orifice Size/Altitude Adjustment

For altitudes above 2,000 feet, the orifice should be de-rated by 4% for every 1,000 feet to maintain the proper ratio of gas to air. Improper orifice sizing may result in damage and unsafe conditions. Changing the orifice should only be done by a qualified service technician. Contact your Lennox Hearth Products dealer for proper orifice sizes (see Page 21 and 24 for more information).

The Firestar™ Insert

- Must conform with all local, state, and national installation codes. In the absence of local codes, the installation must conform with National Fuel Gas Code ANSI Z223.1 - latest edition, also known as NFPA 54. Refer to the National Fuel Gas Code and local zoning and code authorities for details on installation requirements.
- Must conform with the Manufactured Home Construction and Safety Standard, Title 24 CFR, Part 3280, or when such a standard is not applicable, the Standard for Manufactured Home Installations, ANSI A225.1 - latest edition for manufactured (mobile) home installations.
- Must be vented directly to the outside in accordance with the latest edition of the National Fuel Gas Code and must never be attached to a chimney serving a separate solid fuel burning appliance.
- Uses room air for combustion. It is imperative that provisions for adequate combustion and ventilation air be made. This appliance is NOT designed to and will not operate in a negative pressure. Contact your dealer if you suspect such a situation exists.
- Has been certified for use with either natural gas or propane.
- Is not for use with solid fuels.
- Is approved for sitting rooms and/or bedrooms.

Fireplace Requirements

These heaters are designed to be installed into an existing masonry fireplace (built to UBC 37 standards) or factory built solid fuel, wood burning fireplace (listed to UL 127 standards) only. All exhaust gases must be vented outside the structure. Combustion air is drawn from outside the structure. When installing in a factory built fireplace, the fireplace grate must be removed and the damper must be removed or secured open.

If the factory-built fireplace has no gas access hole(s) provided, an access hole of 1-1/2 inches (38 mm) or less may be drilled through the lower sides or bottom of the firebox in a proper workmanship like manner. This access hole must be plugged with a non-combustible insulation after the gas supply line has been installed.

The installer must mechanically attach the marking supplied with the gas fireplace insert to the inside of the firebox of the fireplace into which the gas fireplace insert is installed.

IMPORTANT: When installing these appliances into a factory built fireplace or heat-form, the air flow within and around the fireplace shall not be altered by the installation of the insert (i.e. DO NOT BLOCK louvers or cooling air inlet or outlet ports, circulating air chambers in a steel fireplace liner or metal heat circulator).



Codes & Approvals

CERTIFICATION

Gas appliances must be tested and certified by a nationally recognized testing and certification laboratory to ANSI (American National Standard Institute) gas appliance safety standards.

This insert has been tested and certified by OMNI -Test Laboratories to ANSI Z21.88-2005 Standard for Vented Gas Fireplace Heaters and UL 307B Gas Burning Heating Appliances for Manufactured (Mobile) Homes.

It has met all necessary ANSI Standards and is fully certified for installation in any community. If there are any questions or if you need further substantiation either write to or call your Lennox Hearth Products dealer. If you have further questions, please contact Lennox Hearth Products.

NEW YORK CITY, NEW YORK (MEA)

Installation of these fireplaces are approved for installation in New York City in the US state of New York (MEA#: 138-07-E).

COMMONWEALTH OF MASSACHUSETTS REQUIREMENTS

Installation of these fireplaces are approved for installation in the US state of Massachusetts if the following additional requirements are met -

- Installation and repair must be done by a plumber or gas fitter licensed in the Commonwealth of Massachusetts.
- The flexible gas line connector used shall not exceed 36 inches (92 centimeters) in length.
- The individual manual shut-off must be a T-handle type valve.

Pre-Installation

FEATURES

Installation Options

Residential - Vented Vertical Only
 Manufactured (Mobile) Home
 Natural Gas Or Propane (LP)
 Bedrooms
 Optional Wall-mounted Or Remote Thermostat

Electrical

The fan motor requires 120 Volts AC for operation. The fireplace is not dependent on the fan or an outside electrical supply to operate.

Millivolt Valve

This insert is operated with a millivolt valve and therefore burns even during a power outage.

Fuel

This insert comes from the factory equipped to burn natural gas at a specified elevation. The insert can be converted to burn LP (liquid propane) by installing a conversion kit. Only Lennox Hearth Products conversion kits can be used to convert from NG to LP or LP to NG. Contact your Lennox Hearth Products dealer for details.

PACKAGING LIST

To install a Firestar insert, an insert body, and surround (flange) kit are required.

Insert Body Packaging List

- 1 Insert Body with Burner Cassette and trivet
- 1 Set of Refractory Brick Panels - 3 pieces (H5866)
- 1 Log Set (H5860)
- 1 Lower front 2" filler panel
- 1 Fasteners: 6 slotted 1/4" truss screws
 4 speed nuts
 6 spring clips
 4-3/8" x 3" leveling bolts
 2 socket head screws
- 1 Installation and Operation Manual

Surround Kits - One Required

- 29 X 41" Black Trim (75072)**
- 29 X 48" Black Trim (75073)**
- 33 X 41" Black Trim (75074)**
- 33 X 48" Black Trim (75075)**

Surround Kit Contents

- 1 Top Surround
- 2 Side Surrounds
- 3 Black Trim Pieces
- 2 Elbowed Trim Fasteners

RATINGS	Firestar™ (GC3)	
	NATURAL GAS	LP GAS
MAX/MIN INPUT BTUH 0-2,000 FT (0-610 M) ❶	39,000/27,500	39,000/22,600
MANIFOLD PRESSURE (IN. WC)	1.7 - 3.5	3.5 - 10.0
MIN./MAX. INLET PRESSURE (IN. WC)	5.0 - 10.5	10.5 - 13.0
MAXIMUM HEAT OUTPUT BTUS/ HOUR "STEADY STATE"	31,200	31,200
ORIFICE (DMS) 0-2,000 FT (0-610 M) ❶	#37	#52
❶ Unit factory equipped for 0-2000 FT/0-610 M		

INSERT DIMENSIONS

See Figures 1, 2 and 3 showing insert dimensions and minimum fireplace firebox dimensions to aid you in determining proper fit into existing fireplace.

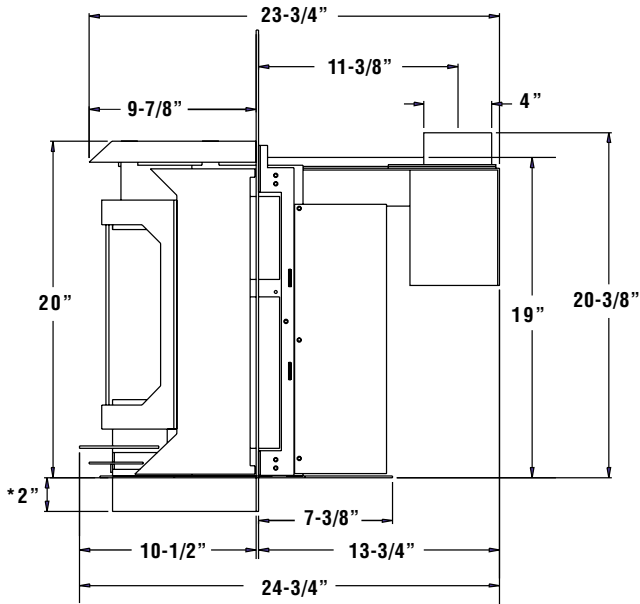

* Equipped from the factory with a 2" filler. Contact your dealer for additional information.

Figure 1

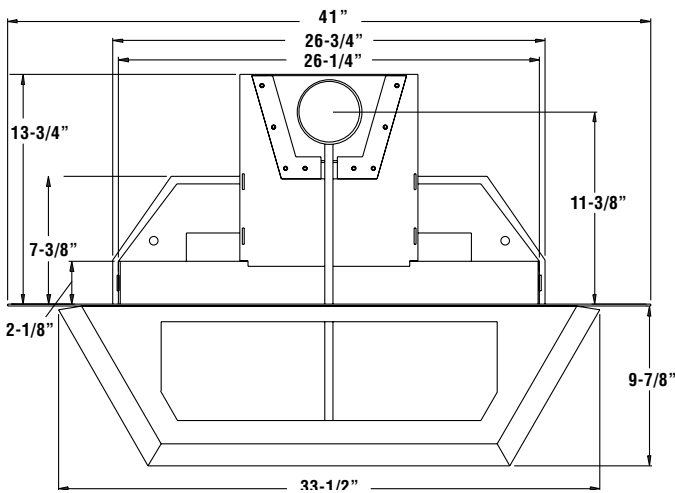

Figure 2

Insert Dimensions	
Width of insert behind Surround Panels	26-3/4"
Rear height	18-7/8"
Insert depth into fireplace	13-5/8"
Flue center line from back of surround with standard draft hood	11-3/8"
Flue collar diameter (OD)	3-15/16"

MINIMUM FIREPLACE CAVITY

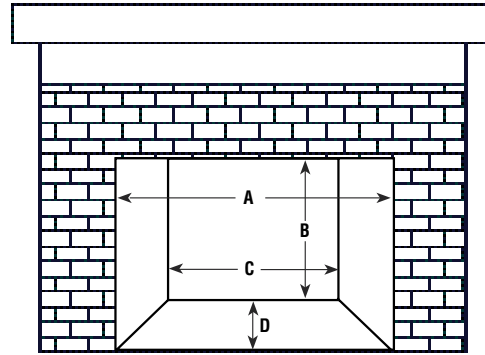

Figure 3

MINIMUM FIREPLACE OPENING REQUIRED

- A = 29-3/4" Front Opening
- B = 19" Height
- C = 19" Rear Width
- D = 15-1/4" Fireplace Depth

⚠ CAUTIONS

- The fireplace in which this gas insert is to be installed must be thoroughly cleaned if it has been used to burn wood or synthetic logs. Have the chimney and all inside surfaces of the fireplace brushed and vacuumed so that no soot, embers, or loose combustion deposits can be drawn into the heat circulation blower and blown into the living area.
- If any portion of the chimney system shows signs of structural or mechanical weaknesses, such as: cracks, leaky joints, corroded or warped surfaces, the faulty portion must be repaired or replaced prior to installing this appliance.
- The factory built firebox must accept the insert without modification other than removing bolted or screwed together pieces such as baffles / smoke shelf / deflectors, ash lips, glass door, screen or door tracks, log grates, refractory or masonry lining and damper assemblies. Any fireplace component, which is removed, must be retained so they can be reinstalled to restore the fireplace to its original operating condition. The removal of any part must not alter the integrity of the outer shell of the pre-engineered fireplace cabinet in any way. Any parts removed must be replaceable. If any components are removed from (or altered) from the existing fireplace, a Warning Label (see Page 4) must be affixed inside the fireplace firebox, so that it shall be visible upon removal of the fireplace insert. Note: RTV high temperature silicone is an approved adhesive to affix the label.

MINIMUM CLEARANCES TO COMBUSTIBLES

The letters below, C through H, correspond to Figure 4 showing minimum clearances required from the appliance to combustibles and the minimum projection of the hearth extension.

- C = 6.5" to Side Facing (3/4" or less)
- D = 11" to Side Wall
- E = 24" to Mantel** (more than 3/4")
- F = 14.5" to Top Facing (maximum thickness 3/4")

HEARTH PROTECTION

- G = Minimum Hearth Protection from Front of Insert*
- H = Vertical Distance from Insert Bottom to Combustible Material.

G	<u>23"</u>	<u>20"</u>	<u>17"</u>	<u>0"</u>
H	<u>0"</u>	<u>2"</u>	<u>4"</u>	<u>6"</u>

(*Insert bottom is the metal lip below the lower gold trim bar).

Note: Hearth protection to be min. 3/8" (10mm) thick non-combustible or equivalent, with a k factor of .84.

INSERT LEVELING

The FireStar™ insert comes with four 3/8" X 3" leveling bolts (two for use at the rear and two at the front of the insert). The two at the rear can be used to raise the back of the insert resting on the fireplace hearth. The two at the front can be used to adjust the front of the insert on the hearth extension. To install the bolts a 3/8" nut should be threaded onto the bolt, followed by a 3/8" flat washer. The bolt should then be installed from the under side of the insert into the captive nut in the bottom of the insert. When the bolt is adjusted to the proper height the nut previously threaded onto the bolt can be snugged up to the insert bottom.

CLEARANCES

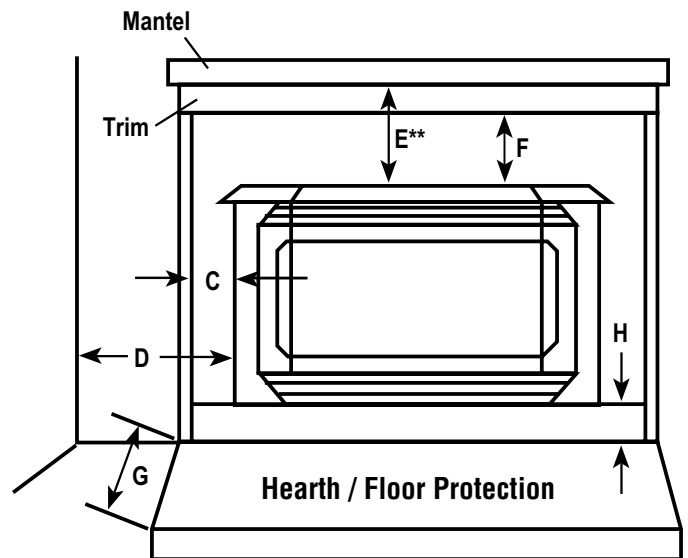

Figure 4

**The minimum distance from the top of the insert to a combustible may be reduced to 16" with a mantel shield. The shield should be made from 18-gage or thicker sheet metal, 7" by 33". The shield must be centered over the insert and spaced one inch below the mantel. The shield can be fastened to and spaced from the mantel using four to six screws.

Installation

INSERT VENTING

Refer to Figure 6 which shows a typical installation of this appliance into an existing solid-fuel fireplace.

WARNING: This appliance is equipped with a safety control system designed to protect against improper venting of combustion products. Operation of this heater when not connected to a properly installed and maintained venting system or tampering with the blocked vent shut-off system can result in carbon monoxide (CO) poisoning and possible death.

Insert must be vented to the outside in accordance with the current edition of the National Fuel Gas Code ANSI-Z223.1-latest edition, also known as NFPA 54. The insert must **not** be connected to a chimney flue serving a separate solid fuel burning appliance.

This gas insert requires a 4" diameter B-vent or listed flex aluminum or stainless chimney liner extending the entire length of the chimney to ensure proper operation. The vent should terminate with a chimney cap or rain cap. Chimney should be sealed around cap to prevent air and rain from entering chimney. Adhere to vent manufacturer's instructions for installation and vent termination.

A minimum flue height of 12 feet is recommended.

The insert must be installed so the draft hood is in the same atmospheric pressure zone as the combustion air inlet to the appliance.

FLUE COLLAR CONNECTION

This insert has a detachable flue collar to ease installation. To detach flue collar lift removable vent (trivet) from top of insert, unscrew draft tube retaining screw (see Figure 5) and slide draft tube and flue collar to the rear. Attach flue collar (with 3 sheet metal screws or a B-vent connector) to vent pipe previously installed in chimney. As the insert is pushed into fireplace guide draft tube and flue collar into guide brackets until draft tube retaining screw can be reinstalled in its original hole.

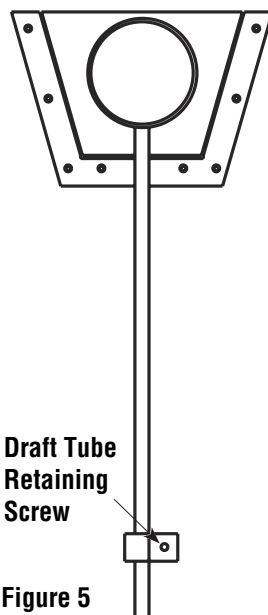

Figure 5

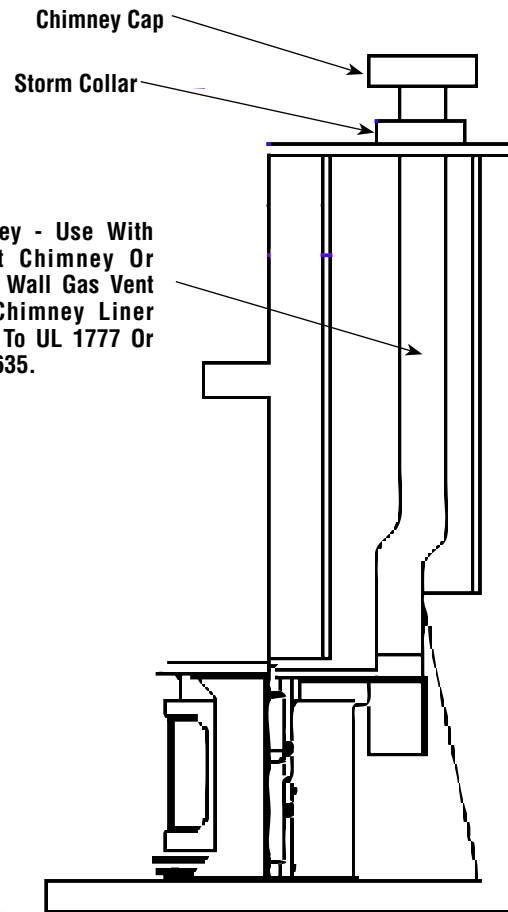

Figure 6

WARNING

Do not substitute the heat-rated flex liner (UL1777 or ULC S635) for the exhaust with any other type liner or a fire may result causing property damage, personal injury or loss of life.

The following vent liner kits are available from Lennox Hearth Products (see Figure 7 and table below).



Figure 7

VENT KITS		
Cat. #	Model	Description
H0906	VKBVI25	BVI, 4" Dia. x 25' Length
H0907	VKBVI35	BVI, 4" Dia. x 35' Length

ZERO CLEARANCE FIREPLACE INSTALLATION

This insert may be installed in a masonry or factory built/zero clearance (ZC) fireplace. When installing in a ZC fireplace, the ZC grate must be removed and the ZC damper must be removed or secured open. The ZC doors, screen, refractory or masonry lining, baffles, and smoke shelf may be removed, if necessary, to install the gas insert. However, **do not cut or alter the fireplace components**. The removal of any parts to facilitate installation must not alter the integrity of the inner or outer shells of the fireplace cabinet. See Fireplace Requirements on page 4.

GLASS DOOR REMOVAL

See page 17 for Glass Door Removal Instructions.

BRICK LINER INSTALLATION

HANDLE THE BRICK PANELS WITH CARE (SEE FIGURE 8) AS THEY ARE FRAGILE. DO NOT FORCE THE PANELS INTO THE FIREBOX AS THEY WILL BREAK IF FORCED.

1. Open and remove glass door, see "Front Door Removal"
2. The longest panel goes in the rear of the firebox. Tilt the top of the panel forward, insert the bottom of the panel in the brick panel retainer and push the panel to the upright position.
3. Install the side panels by sliding the top of the panel into the top side brick retainer and then dropping the bottom of the panel into the bottom retainer. The rounded edge on the side brick panels goes toward the front.

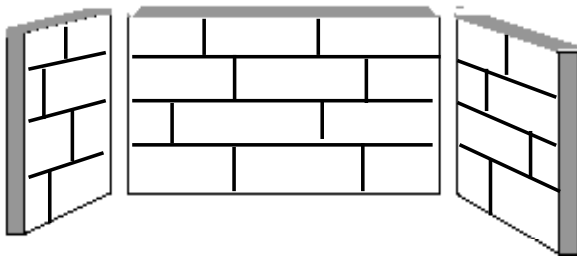

3-Piece Brick Panel Set

Figure 8

LOG INSTALLATION INSTRUCTIONS

CAUTION: If the logs are not properly installed, your insert will not function properly.

Part list: Rear log, Right Front log, Left Front log, and Top Twig

1. Remove the logs from the box and carefully unwrap them. The logs are fragile, so handle them with care.
2. Place the rear log with the charred surface forward, on the two rear locating pins (see Figure 9).
3. Place the left front log, with the charred surface forward, (see Figure 10) on the two left front locating pins. Next place the right front log, with the charred surface forward, on the two right front locating pins.

Continued on Page 10...

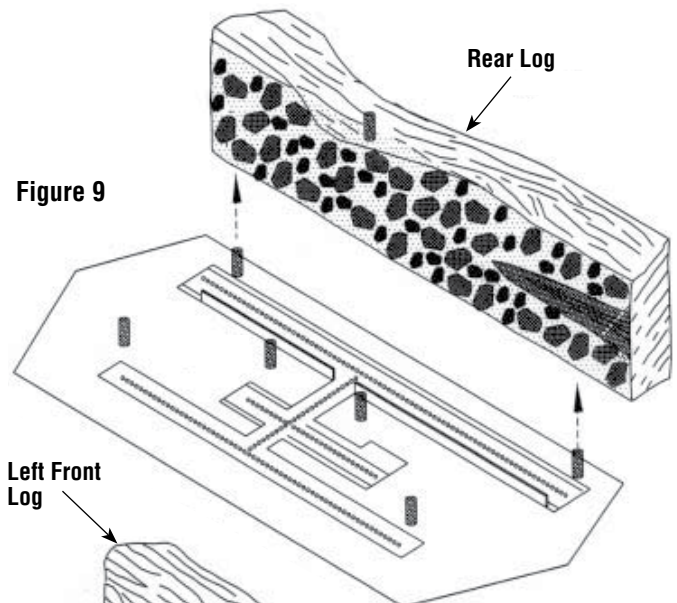

Figure 9

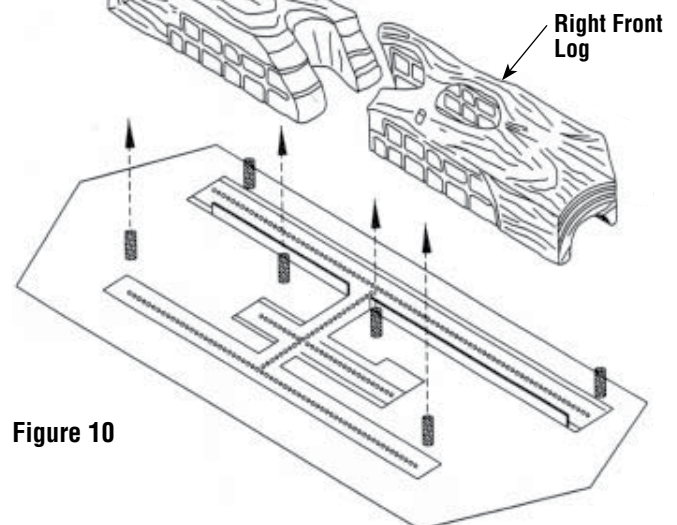

Figure 10

LOG INSTALLATION CONTINUED (GC3)

- Position the top twig, with the charred end forward, on the pin in the top of the rear log and the pin in the top of the right front log (see Figure 11).
- Place the volcanic stone one high in front of the front burner tube (see Figure 12). Take care not to cover all the burners ports. Any extra volcanic stone may be placed at the ends of the front logs, off the burner. Place small pinches of rockwool (embers) on top of the volcanic stone.

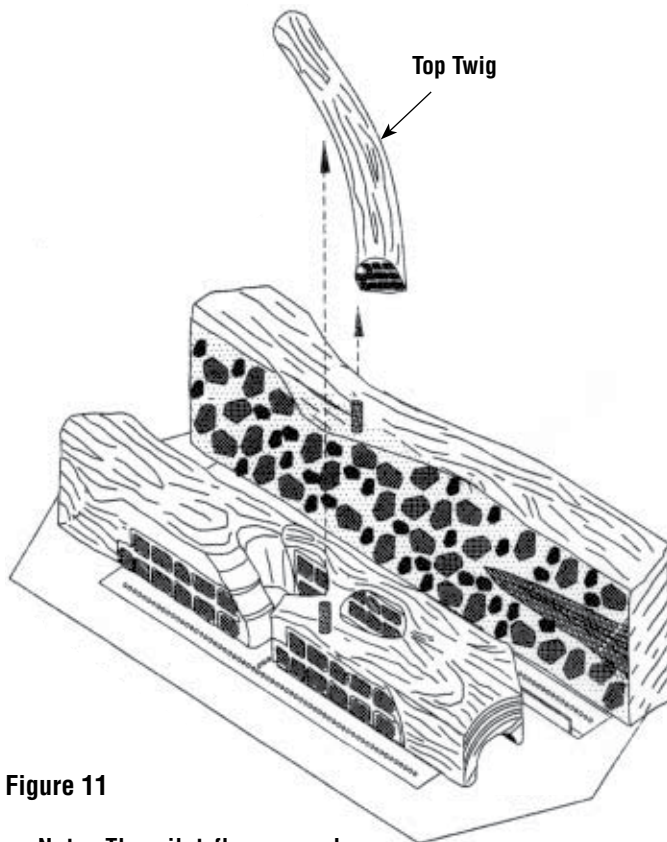

Figure 11

Note: The pilot flame can be viewed through the burned hole in the right front log.

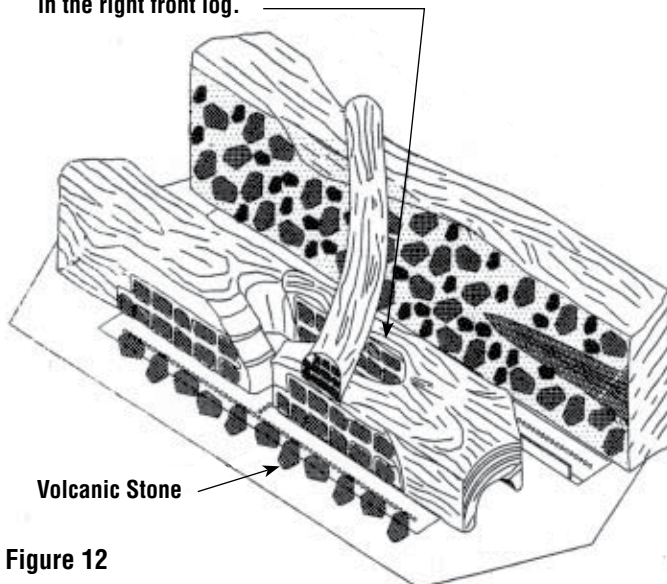

Figure 12

SURROUND INSTALLATION

Install per the following instructions (refer to Figure 13).

The FireStar™ insert flanges are made of heavy 12 gage steel for durability and, if desirable, for the ease of making an inside fit in the fireplace. See "Packaging List" for sizes available. The side flanges extend 2" below the bottom of the insert and align with the 2" lower filler panel. In those few instances when the elevation of the hearth necessitates, 2" can be cut from the bottom of the side flanges and the insert placed directly on the hearth- not using the leveling bolts or filler panel.

- Remove the speed nuts from the parts bag and install (with the flat surface forward) on the six holes in the flange brackets (three on each side of the insert). A flat bladed screwdriver may help in installing the nuts.
- Install all flanges and trim with the insert positioned in the fireplace but a few inches in front of its final location.
- Open side doors and install the side flanges by lining up the holes in the tabs on the side flanges in front of the holes on the flange brackets. (Note that the larger tab on side flange goes at the bottom and the front leveling bolts need to be raised to at least two inches to accommodate the length of the side flanges). Next insert two slotted 1/4" truss screws for each side flange and secure loosely.
- Fasten top flange with the remaining two truss screws. Tighten all six truss screws after shifting flanges to eliminate space between side and top flanges.
- Install two spring clips approximately five inches from each end of each of the three gold trim pieces. The spring clips should be installed in the channel of the trim with the curved end to the front toward the rounded surface of the trim.
- Place the longest trim piece with the rounded surface out along the edge of the top flange with the spring clips slightly behind the flange. Pull the trim forward, compressing the spring clips, and slide the trim down onto the flange.
- Insert the elbowed retainer in the mitred end of the side trim pieces and fasten with flat screwdriver. Insert the other end of the retainer in the end of the already installed top flange and slide side trim onto the edge of the side flange compressing spring clips in the process. Repeat the same steps for the other side trim. Fasten the elbowed retainer securely in the top flange making a nice mitred corner.

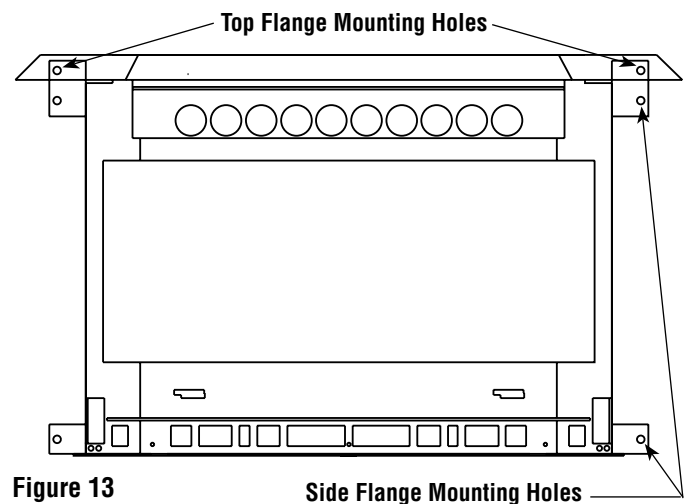

Figure 13

Side Flange Mounting Holes

LOWER FRONT 2" FILLER PANEL

The FireStar™ insert comes with a 2" panel to fill the space between the insert bottom and the hearth extension. If the hearth elevations necessitate, the insert may be installed directly on the hearth without the leveling bolts or filler panel. To install the panel, insert the four tabs on the top of the panel into the corresponding slots in the insert bottom. Open the insert side doors, remove the two socket head screws from the hardware bag and install them (using a 5/32" hex wrench) through the insert bottom into the filler panel. A tall adjustable filler panel is also available.

GAS LINE INSTALLATION

After leveling, position the insert in the fireplace, holding it about six inches out from its final location.

Caution: Specific Hearth Requirements apply (see Clearances and Specifications). The Firestar gas insert must be connected to the gas line in accordance with local codes and / or the National Fuel Gas Code, Z223.1-latest edition, also known as NFPA 54. Included in the manual package is an 8" gas nipple. Locate the threaded gas inlet on the lower left of the insert. Thread the 8" gas nipple into the inlet with a teflon sealer or equivalent. Attach the gas supply line to this hard pipe. The hard pipe can receive a 3/8" inch female iron pipe coupling, or a shut off valve. After connecting the gas line, all joints in the line and connections at the valve should be checked for leaks.

GAS PRESSURE REQUIREMENTS

A MAJOR CAUSE OF OPERATING PROBLEMS WITH GAS APPLIANCES IS IMPROPER GAS PRESSURE!

The most important item to check during the initial installation and the first thing to check when operating problems occur is gas pressure! This appliance will not function properly unless the required gas pressure is supplied. See Table 1 for gas pressure requirements.

Two pressure taps are provided on the insert's valve to check gas pressures. The taps are located below the on/off/pilot knob (see Figure 14). The left tap is the inlet (supply) pressure side. To check inlet pressure (with the insert burning), insert a small phillips screwdriver into the tap and turn a half turn counter-clockwise. Cover the tap with the line from a manometer and check the pressure. Close tap gently but securely after completing the check. The manifold (outlet) tap is to the right of the inlet tap. To check manifold pressure (with the insert burning at the high burn setting) insert a small phillips screwdriver into the tap and turn a half turn counter-clockwise. Cover the tap with the line from the manometer and check the pressure. Again close the tap gently but securely after completing the check. Check the taps for gas leaks with a gas leak test solution (retighten if necessary).

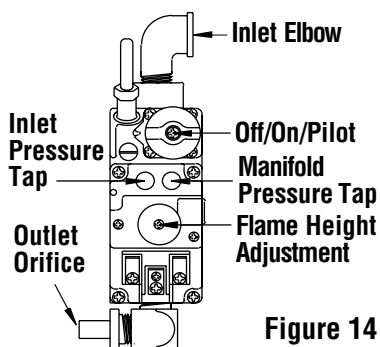

Figure 14

NOTE: DIAGRAMS & ILLUSTRATIONS ARE NOT TO SCALE.

If the pressure is not sufficient, make sure the gas supply line is large enough, the supply regulator is properly adjusted, and the total gas load for the residence does not exceed the amount supplied.

The appliance and its individual shut off valve must be disconnected from the gas supply piping system during any pressure testing of that system at test pressures in excess of 1/2 psig.

The appliance must be isolated from the gas supply piping system by closing its individual manual shut-off valve during any pressure testing of the gas supply piping system at test pressures equal to or less than 1/2 psig. Check with your gas supplier or plumber.

Fuel Type	Inlet Pressure			Manifold Pressure	
	Desired	Minimum	Maximum	On Hi Fire	On Lo Fire
Natural Gas	7" WC	5" WC	10.5" WC	3.5" WC	1.7" WC
LP Gas	11" WC	10.5" WC	13" WC	10.0" WC	5.4" WC

Table 1

GAS SUPPLY LINE SIZING

The proper gas line diameter must be selected to run from the supply regulator to the insert. Refer to the Table 2 for proper gas pipe diameters.

NOTE: Some areas allow copper tubing - check with local approval agencies and codes.

COPPER TUBING NOT ALLOWED IN MASSACHUSETTS IN NATURAL GAS INSTALLATIONS, NEVER USE GALVANIZED OR PLASTIC PIPES.

Pipe Length (Feet from Supply Regulator)	Schedule 40 Pipe Inside Diameter (Black Pipe)		Tubing, Type L Outside Diameter (Copper) (Do Not Use Copper in Massachusetts with Natural Gas)	
	Natural Gas	L.P.	Natural Gas	L.P.
0-10	1/2" (1.3 cm)	3/8" (1.0 cm)	1/2" (1.3 cm)	3/8" (1.0 cm)
10-40	1/2" (1.3 cm)	1/2" (1.3 cm)	5/8" (1.6 cm)	1/2" (1.3 cm)
40-100	1/2" (1.3 cm)	1/2" (1.3 cm)	3/4" (2.0 cm)	1/2" (1.3 cm)
100-150	3/4" (2.0 cm)	1/2" (1.3 cm)	7/8" (2.3 cm)	3/4" (2.0 cm)
150-200	3/4" (2.0 cm)	1/2" (1.3 cm)	7/8" (2.3 cm)	3/4" (2.0 cm)

Table 2

PROPANE (LP) AND NATURAL GAS SUPPLIES

Your Firestar™ gas insert is equipped from the factory for use with natural gas only as specified on the Safety / Listing label attached to the appliance. This appliance can only be operated using propane gas (LP) if a certified fuel conversion kit provided by Lennox Hearth Products is installed by a qualified service technician.

Also check the orifice size on the label attached to your control panel. It must be the correct size for the fuel and altitude.

Do not run propane tank dry. Running the tank dry may cause a hazardous condition due to pressure drop in empty tank.

Solid fuel is NOT to be used with this unit.

AIR SHUTTER ADJUSTMENT

The main burner has an adjustable air shutter located at the end of the burner as it inserts over the orifice. It is located behind the right side door and beneath the control valve. The shutter adjustment has been set at the factory to ensure proper, safe combustion and flame pattern. Only a qualified gas technician should adjust the air shutter as an incorrect adjustment could cause a hazardous condition. Closing the air shutter will cause the flames to take on a yellow color. Closing it too far will cause improper burning and the flames will turn orange and sooty. Opening the air shutter will cause the flames to burn cleaner; becoming transparent and bluish.

Caution: The air shutter should never be closed to such an extent to create sooting on the viewing glass, logs or heat exchanger. If soot begins to form after burning, the air shutter should be opened gradually until the sooting condition stops. Open the shutter a small amount at a time until the sooting ceases. See “Flame Color and Behavior” and “Maintenance”, proper pilot flame.

1. Remove glass door (see Glass Door Removal on page 17). Carefully remove the log set and set aside.
2. Using a 5/32" allen wrench, remove the allen-head screw on the left side of the air control panel as shown in Figure 15a, then lift out air control panel as shown in Figure 15b.
3. Using a 5/32" allen wrench, remove the screw which secures burner tube assembly as shown in Figure 15c. Then lift out burner tube assembly as shown in Figure 15d.
4. Using a phillips screwdriver, loosen the air shutter setscrew just enough so air shutter can be rotated by hand (read note below). See Figures 15e and 15f.
5. Reinstall components by reversing steps 1 - 4.
6. Locate the air shutter, behind the right side access door (below valve), then adjust the air shutter gap until the proper flame characteristics are achieved.

Note: The setscrew for the air shutter is secured tightly from the factory so that it does not rotate from the factory setting during shipping. Once you loosen the setscrew just enough so that it can be rotated by hand, then reinstall the burner tube, you will be able to access and adjust the air shutter from behind the right side panel (below valve).

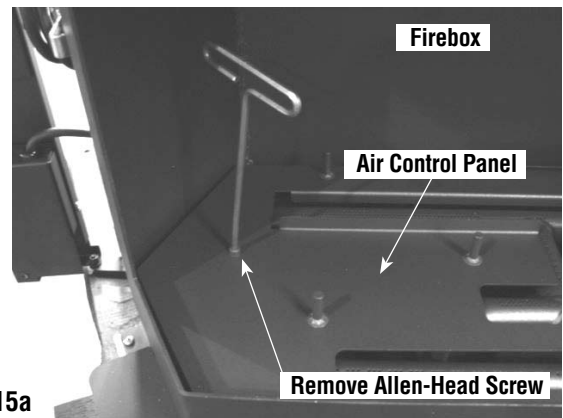

Figure 15a

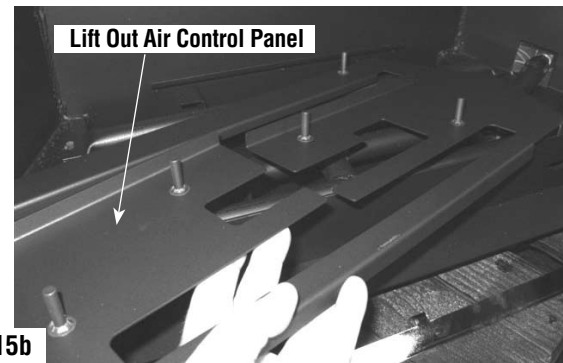

Figure 15b

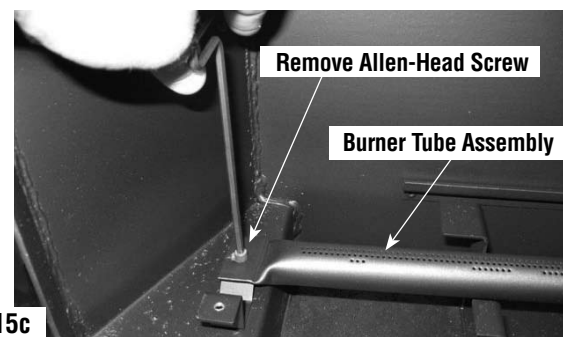

Figure 15c

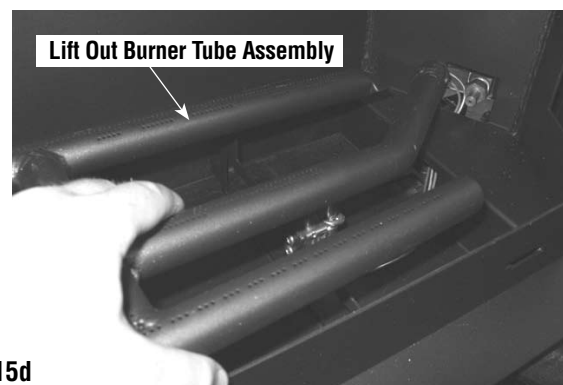

Figure 15d

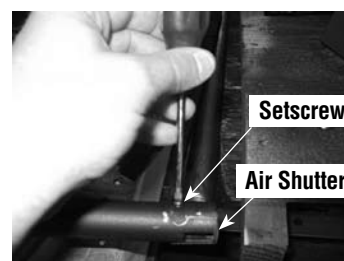

Figure 15e



Figure 15e

Operating Instructions

PRE-LIGHTING CHECKLIST

Be sure to check these items before the initial lighting of the insert:

- All packaging materials are removed from the firebox; brick panels and logs are installed.
- The insert gas label must correspond to the gas supply available, that is "natural gas" for natural gas; "LP gas" for LP gas.
- Be sure the gas pressure has been carefully checked (see Gas Pressure Requirements).
- Fingerprints or other marks are cleaned (while the insert is cool) from any gold or nickel surfaces with denatured alcohol and a soft cloth. Marks left on these surfaces may become etched into the finish if not removed prior to burning the unit.
- Check all gas fittings for leaks.
- Remove all combustible materials from the area in front of the insert and ensure the vented areas of the insert face are unobstructed.
- Check to ensure all clearances to combustibles are met—see page 7.
- Make sure the glass door is in place and properly sealed before burning the appliance.
- Ventilate the house to clear initial paint curing odors, see page 15.

Lighting Instructions

The following is a copy of the operating and lighting instructions found with each insert:

FOR YOUR SAFETY READ BEFORE OPERATING

WARNING: IF YOU DO NOT FOLLOW THESE INSTRUCTIONS EXACTLY, A FIRE OR EXPLOSION MAY RESULT CAUSING PROPERTY DAMAGE, INJURY, OR LOSS OF LIFE.

CAUTION: HOT WHILE IN OPERATION. DO NOT TOUCH. KEEP CHILDREN, FURNITURE, GASOLINE, AND OTHER LIQUIDS WITH FLAMMABLE VAPORS AWAY. NEVER OPERATE UNIT WITH GLASS OFF OR ATTEMPT TO REMOVE THE GLASS WHILE HOT.

- A. This appliance is equipped with a piezo ignition device to light the pilot. When lighting the pilot, follow these instructions exactly.
- B. **BEFORE LIGHTING**, smell around the appliance area for gas. Be sure to smell next to the floor, because some gas is heavier than air and will settle on the floor.

WHAT TO DO IF YOU SMELL GAS:

DO NOT try to light the appliance.
DO NOT touch any electric switch,
DO NOT use any phone in the building. Immediately call your gas supplier from a neighbor's phone. Follow the gas supplier's instructions. If you cannot reach your gas supplier, call the fire department.





- C. Use only your hand to push in or turn the gas control knob. Never use any tool. If the knob will not push in or turn by hand, don't try to repair it, call a qualified service technician. Force or attempted repair may result in a fire or explosion.
- D. **DO NOT** use this appliance if any part has been under water. Immediately call a qualified service technician to inspect the appliance and to replace any part of the control system and any gas control which has been under water.

OPERATING INSTRUCTIONS

(Refer to controls shown in Figure 16)

CAUTION: Your Lennox™ gas INSERT MUST ALWAYS BE OPERATED WITH GLASS IN PLACE.

STOP!! Read the safety information above before proceeding.

1. Open the lower door. Make sure gas supply shut-off cocks are open and ON/OFF rocker switch is "OFF." If equipped with a thermostat, set it to the lowest setting.
2. Turn off all electrical power to the appliance.
3. Push in gas cock dial slightly and turn clockwise  to "OFF."
NOTE: Dial cannot be turned from "PILOT" to "OFF" unless dial is pushed in slightly. Do not force.
4. Wait five minutes to clear out any gas. Then smell for gas, including near the floor. If you smell gas, STOP! Follow "B" above. If you don't smell gas continue.
5. Locate the pilot by looking over the top of the left front log. A blue flame will be seen when the pilot is lit.
6. Turn the gas control knob counter-clockwise  to the "PILOT" position.
7. Push the knob all the way in and hold in that position. Immediately light the pilot by pressing the igniter button several times until pilot is lit. Continue to hold the knob in for about 30 seconds after the pilot is lit. Release knob and it will pop back out. Pilot should remain lit. If it goes out, repeat steps 4-8 holding knob in an additional 15 seconds after pilot is lit. If knob does not pop out when released, stop and immediately call your service technician or gas supplier. If the pilot will not stay lit after several tries, turn the gas control knob to "OFF" and call your service technician or your gas supplier.
8. After pilot is lit, turn gas control knob counter-clockwise  to "ON." Knob can only be turned to "ON" if the knob has popped out.
9. To turn burner on, turn "ON/OFF" rocker switch to "ON" or set the thermostat to the desired temperature above room temperature.
10. Adjust the flame height (and heat output) by turning the flame height knob clockwise  for full flame and counter-clockwise  for reduced flame.
11. Turn on the electric power to the appliance and set the blower to the desired air flow after it turns on when the appliance reaches operating temperature.

TO TURN OFF GAS TO APPLIANCE

(Refer to controls shown in Figure 16)

1. Turn off the "ON/OFF" rocker switch and/or thermostat (if installed) to its lowest setting.
2. Turn off electric power to the appliance if service is to be performed.
3. Push in gas control knob slightly and turn clockwise  to "OFF." Do not force.

This appliance needs fresh air for safe operation and must be installed so there are provisions for adequate combustion and ventilation air.

WARNING: Improper installation, adjustment, alteration, service, or maintenance can cause injury or property damage. For assistance or additional information, consult a qualified installer, service agency, or your gas supplier.

Operation of this appliance when not connected to a properly installed and maintained venting system can result in carbon monoxide (CO) poisoning and possible death.

SHUTDOWN PROCEDURE

To turn off the burner, turn the rocker switch to "OFF" or adjust the thermostat (if installed) to a setting below room temperature. The pilot will remain lit for future burner ignition. For complete shutdown, see "TO TURN OFF GAS TO APPLIANCE" above.

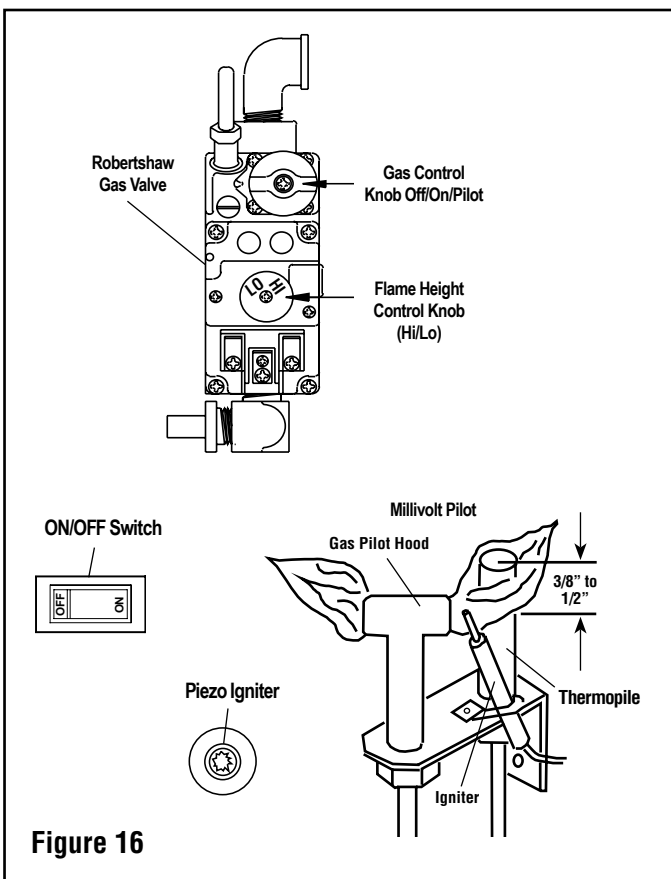

Figure 16

FLAME COLOR & BEHAVIOR

Your Firestar™ gas insert is designed for maximum heating efficiency. Therefore, upon lighting of the main burner the flames will be semi-transparent or "bluish." After 10-20 minutes of operation the logs will heat up and the flames will become a yellow/orange color.

Adjusting the insert to cause the flames to turn orange sooner may result in poor combustion, sooting, and a hazardous situation. See Figure 17 showing proper flame appearance.

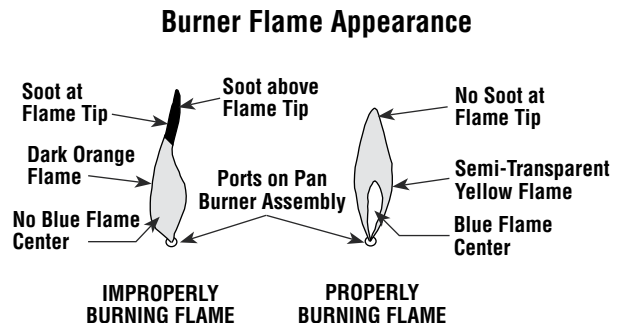

Figure 17

REPLACING BURNER ORIFICES

To change orifices, first remove the cassette (see Fuel Conversion and Cassette Installation on page 19). Then unscrew orifice using a 3/4" open end wrench, discard the old orifice and reinstall the new orifice.

REDUCING THE ORIFICE SIZE FOR HIGHER ALTITUDES MAINTAINS THE PROPER BTU INPUT TO AIR RATIO. TOO LARGE AN ORIFICE WILL RESULT IN HIGHER BTU INPUTS THAN THE DESIGN ALLOWS, MAY RESULT IN AN UNSAFE CONDITION AND MAY VOID YOUR WARRANTY.

For altitudes above 2,000 ft. (610M) the appliance should be derated by four (4%) percent every 1,000 ft. (305M).

To operate safely, your Firestar gas insert must have the proper burner orifice size determined by the altitude at which it will be operated and other variables such as pressure and valve tolerances. If you have reason to believe your insert's orifice size may be incorrect for your altitude, have it checked and remedied (if necessary) by a qualified service technician.

PAINT CURING

This insert has been painted with Stovebright high temperature metallic stove paint. It leaves the factory dry to the touch, but finishes curing as the insert is used. Fire the insert four successive times for ten minutes each time with a five minute cool down between each firing. Ventilate the house during these first firings as the paint gives off carbon dioxide and unpleasant odors. It is recommended that persons sensitive to an imbalance in the indoor air quality avoid the insert during the curing process.

QUIET OPERATION

GAS NOISE: The sound of gas flowing through the insert may be detectable while the unit is in operation. This is a normal operating sound, however if it is objectionable, it can be reduced by turning down the flame. Turning down the flame will reduce heat output.

BLOWER NOISE: As the insert heats up, the blower will come on to move hot air through the heat exchanger and into the room. Adjust the fan speed with the fan control knob to the sound level and air flow desired.

BLOWER

Your Firestar™ gas insert comes equipped with a 150 CFM blower with a variable speed control and an automatic temperature activated On / Off snap switch.

Operation:

1. Plug the blower power cord into a grounded (three prong) outlet. This appliance is equipped with a three prong (grounding) plug for your protection against shock hazard and should be plugged directly into a properly grounded three - prong receptacle. Do not cut or remove the grounding prong from this plug.
2. After the insert warms up, the fan will come on if the speed control (located at the bottom of the left side door) is left in the on position. The fan will not operate until the insert is warm.
3. Once the fan comes on, turn the knob to the desired speed. No further adjustment is necessary, the fan will come on automatically whenever the insert is warm.
4. If you do not wish to have the fan on, turn the knob until it clicks into the OFF position.

“ON-OFF” SWITCH AND THERMOSTAT

Your gas insert comes equipped with an “ON-OFF” rocker switch used to turn the burner on and off while the pilot is on. The switch is located behind the right side door to the right of the control valve. This switch can be relocated to the hole provided in the top surround panel by pulling the two connectors off of the spades on the back of the switch. Then unscrew the plastic nut on the back side of the switch and pull the switch forward through the hole. Cut the wire tie holding the switch wire and feed the wire behind the side flange up to the switch hole in the top flange. Care must be taken to ensure the wire is kept away from the heat of the firebox. Reinsert the switch in the hole in the flange, tighten the retaining nut, and push the wire connectors back on the spades. The spades may need to be carefully bent downward to provide clearance between the switch and the fireplace facing material.

A millivolt wall thermostat or remote thermostat can be used to supplement the rocker switch. The thermostat and rocker switch will turn the burner on and off independently of each other. Be sure to set the rocker switch to the off position when using the thermostat and set the thermostat to the lowest temperature when you wish to use the rocker switch only, otherwise one may override the other.

Follow the instructions included with the thermostat for wiring. Solder all connections, as good wire connections are critical in millivolt system. Check with your insert dealer for the proper length and size of the thermostat wire. Both factors effect the function of the thermostat.

PILOT ADJUSTMENT

All pilots are burned and checked at the factory prior to shipment. (NOTE: If upon initial insert installation the pilot flame flickers or will not remain lit, most likely the pilot is fine but there is air in the gas line or the gas pressure is too low). Pilot adjustment is not normally required, but should it be necessary, it should be done only by a qualified service technician. The pilot adjustment screw is located to the left of the ON/OFF/PILOT control knob. With a flat bladed screwdriver, remove the pilot adjusting cover to access the pilot adjusting screw. Adjust pilot screw to the properly sized flame as shown in Figure 18. The flames should completely surround the thermopile and extend across the main burner ports. Be careful not to back the adjusting screw out of its threads. Replace the cover and check for gas leaks.

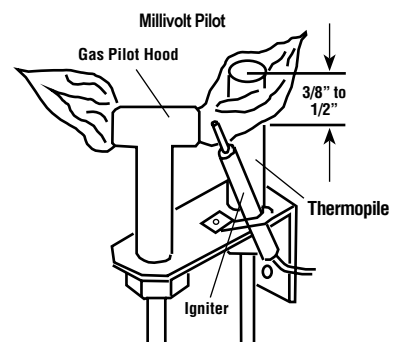

Figure 18

NOTE: DIAGRAMS & ILLUSTRATIONS ARE NOT TO SCALE.

Do not splice any millivolt wires. Refer to Table 3 to determine the proper gage of wire for the thermostat or wall switch connections. This table refers to the total length of the wire (out to the switch and back). The thermostat must be a millivolt type. A 24-volt furnace thermostat will not work. Never hook up household current, 120 Volts, to the millivolt system. It is not recommended to hook up any more than two switches to the insert (for example a rocker switch and a wall thermostat). Additional switches may affect the system resistance and increase the chance of the burner not igniting. Follow the instructions included with the thermostat or remote control for wiring.

The thermostat, remote control, and rocker switch will turn the burner on and off independently. Be sure to set the rocker switch to the "OFF" position when using the thermostat or remote control and set the thermostat or remote control to the lowest temperature when you wish to use the rocker switch only, otherwise one may override the other. If a remote thermostat is to be used with the insert, do not place the receiver under the firebox.

Thermostat Wire	
Wire Size	Maximum Length
12 Gage	100 Feet
14 Gage	64 Feet
16 Gage	40 Feet
18 Gage	25 Feet
20 Gage	16 Feet

Table 3

MILLIVOLT CONTROL SYSTEM

This insert operates on a millivolt control system. As such, no addition power supply is needed for the insert to operate. The pilot assembly contains a **Thermopile**, that when heated by the pilot flame, generates electricity (millivolts, mV=1/1000 of a volt) that travels to terminal #1. From this terminal it travels through a black wire to the **Vent Safety Snap Switch**. If this switch overheats through a flue blockage or vent pipe disconnection it will open, stop the flow of mV and shut the insert off. This switch will automatically reset (close), when it is cooled down to normal operating temperature. During normal operation, it is closed allowing the mV to flow back to the valve, which opens so gas can flow through.

To check for proper operation, use a multimeter and perform the system checks shown in Table 4 (and refer to Figure 19).

Millivolt and System Checks				
Check Test	To Test	Connect Meter Leads to Terminals	Thermostat Connects	Meter Reading Should Be
A	Complete System	2 & 3	Closed	100 MV or More
B	Thermopile Output	1 & 2	Open	Greater Than 325 MV
C	System Resistance	1 & 3	Closed	80 Ohms

Table 4

MILLIVOLT WIRING DIAGRAM

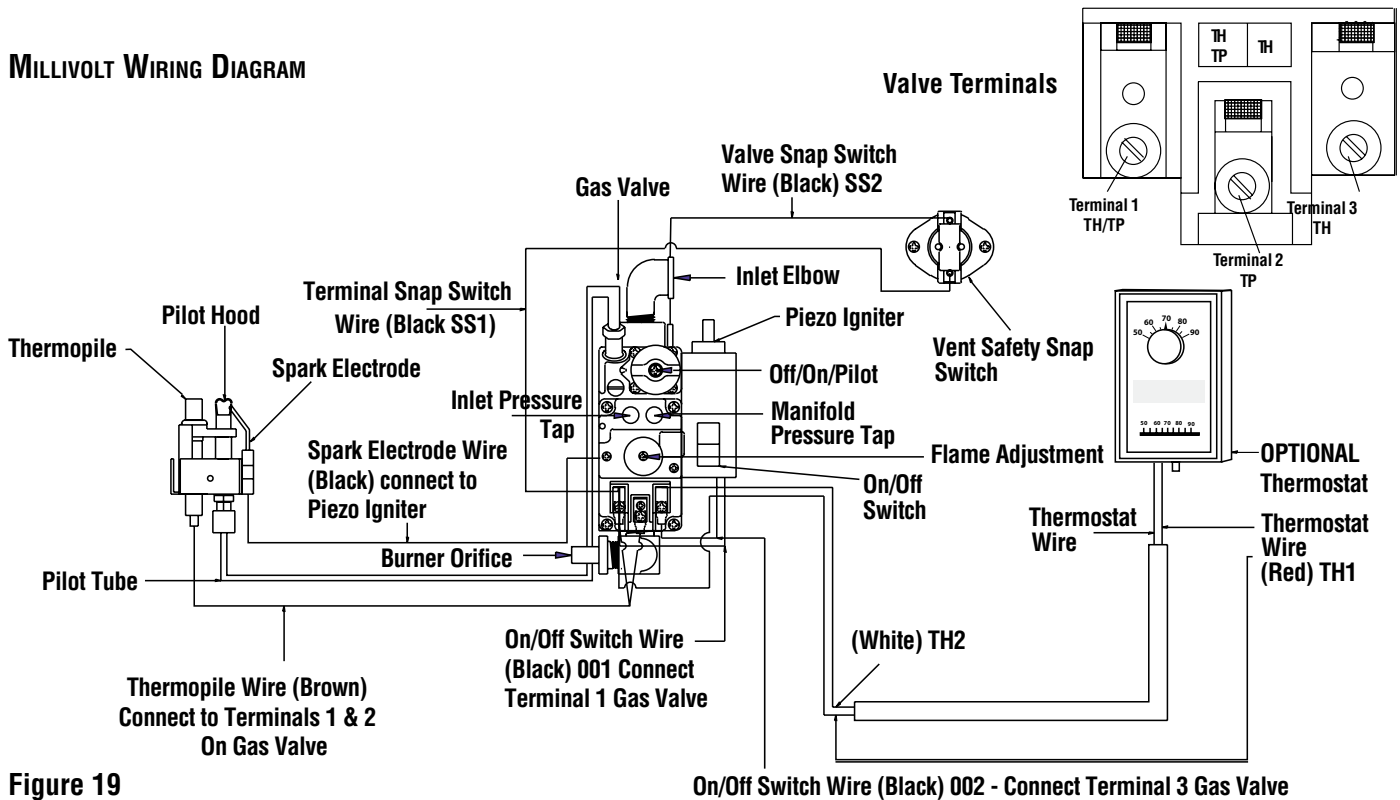

Figure 19

NOTE: DIAGRAMS & ILLUSTRATIONS ARE NOT TO SCALE.

Maintenance & Servicing

MAINTENANCE CHECKLIST

Should Only Be Performed by a Qualified Service Technician.

Caution: Label all wires prior to disconnection when servicing controls. Wiring errors can cause improper and dangerous operation. Verify proper operation after servicing.

1. Annual inspection should be made and the following checks performed:

- With unit cool, remove glass and inspect burner for dirt, soot, and lint accumulations and remove if necessary. If excessive soot accumulation is present on burner, have a qualified serviceman adjust burner for proper combustion.
- Clean any deposits from inside glass with gas fireplace glass cleaner. NEVER attempt to remove or clean glass when the unit is hot.
- Check that chimney and its outlet are open and free from soot, blockage, or debris.
- Inspect the pilot system for proper flame. See instructions on page 15.
- Check the Millivolt system as per Table 4 on page 16.
- The appliance area must be kept clear and free of combustible materials, gasoline, and other flammable vapors and liquids.
- Check glass gaskets once a year. Gaskets must be tight. Replace if necessary.

2. The viewing glass should be cleaned periodically (see Glass Maintenance).

GLASS MAINTENANCE

Cleaning: When cool, the glass may be cleaned with a clean, soft cloth and Windex. For cleaning white condensation from the interior glass, use KEL KEM gas fireplace glass cleaner available from your insert dealer. Use of caustic or abrasive cleaners may damage the glass. DO NOT operate the insert with broken glass. DO NOT clean door or glass when hot. DO NOT abuse the glass door by striking or slamming it shut. DO NOT use substitute materials if replacing the glass. DO NOT spray commercial glass cleaner with ammonia on the door and glass gasket as it may dissolve the gasket glue.

Replacement: The glass in the insert door cannot be replaced separately. Should the glass be damaged, the entire glass, gasket, and metal frame assembly must be replaced as a unit. This replacement glass assembly is available from your Lennox Hearth Products dealer. The glass is neo-ceramic and alternative types must not be used.

WARNING: Do not operate appliance with the glass panel removed, cracked, or broken. Do not remove glass door while the insert is hot. Replacement of the glass door should be done by a qualified service technician.

GLASS DOOR REMOVAL (refer to Figures 20a and 20b)

Caution: Do not slam or strike glass door or damage may occur.

Do not remove the glass door while the insert is hot. Open both latches on the right and left side of the door (they are centered on the sides of the front door - see Figure 20a). With the latches released, rotate the catch part of each latch outward away from the front door. The door will pivot toward you from the top (hinging from the bottom as shown in Figure 20b). On the bottom of the door there are tabs that slide into slots on the firebox. Disengage the tabs on the door from the slots on the firebox by lifting up on the door until it stops and slide the door all the way to the left. You can then remove the door straight out from the slots. To reinstall door reverse the steps above.



Open the top door latches by pulling them forward and up.

Figure 20a

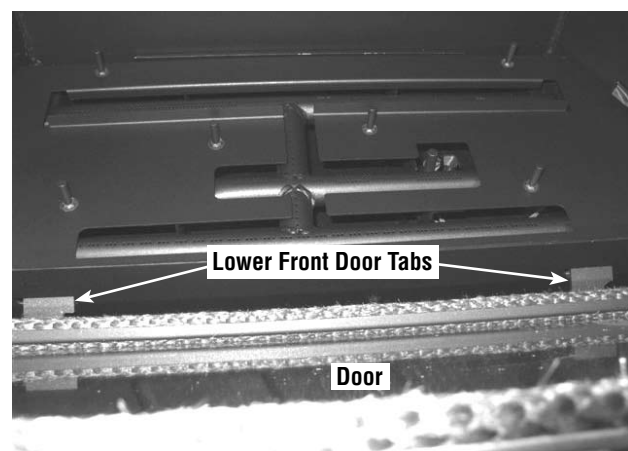

Lift the glass door up and off the lower spring latch

Figure 20b

To remove the front door open the side doors, release the front door latches on either side and rotate the top of the glass door forward and down until it stops. Once it is all the way open, lift it slightly, move it to the left and pull it away from the insert. Place door on a nonabrasive surface being careful not to damage door or glass. When cooled the exterior glass may be cleaned with a clean, soft cloth and windex. For cleaning white condensation from the interior glass use KEL KEM gas fireplace glass cleaner available from your insert dealer. Use of caustic or abrasive cleaners may damage glass.

NOTE: BE CAREFUL NOT TO SPRAY COMMERCIAL GLASS CLEANER WITH AMMONIA ON GASKET AREA OF DOOR. AMMONIA WILL DISSOLVE GASKET GLUE.

NOTE: GOLD PLATED SURFACE MUST BE CLEANED WITH GLASS CLEANER AND SOFT RAG BEFORE FIRING THE FIRST TIME OR FINGER PRINTS AND STAINS WILL REMAIN PERMANENTLY. NEVER USE BRASS POLISH TO CLEAN GOLD, THIS WILL REMOVE GOLD PLATING!

Front door glass replacement should be completed only by a qualified technician.

GLASS DOOR CLEANING AND REPAIR

Cleaning: Do not remove or clean the glass door when hot. A gas door glass cleaner (available from your Lennox Hearth Products dealer) or windex should be used with a soft cloth to clean the glass. Do not use an abrasive cleaner.

Repair: If the glass is broken in the glass door, the entire door (metal frame, gasket, and glass) should be replaced as a unit. This replacement unit is available from your Lennox Hearth Products dealer. Do not use substitute parts or materials.

Caution: Do not operate this insert with broken glass.

BLOWER WIRING DIAGRAM

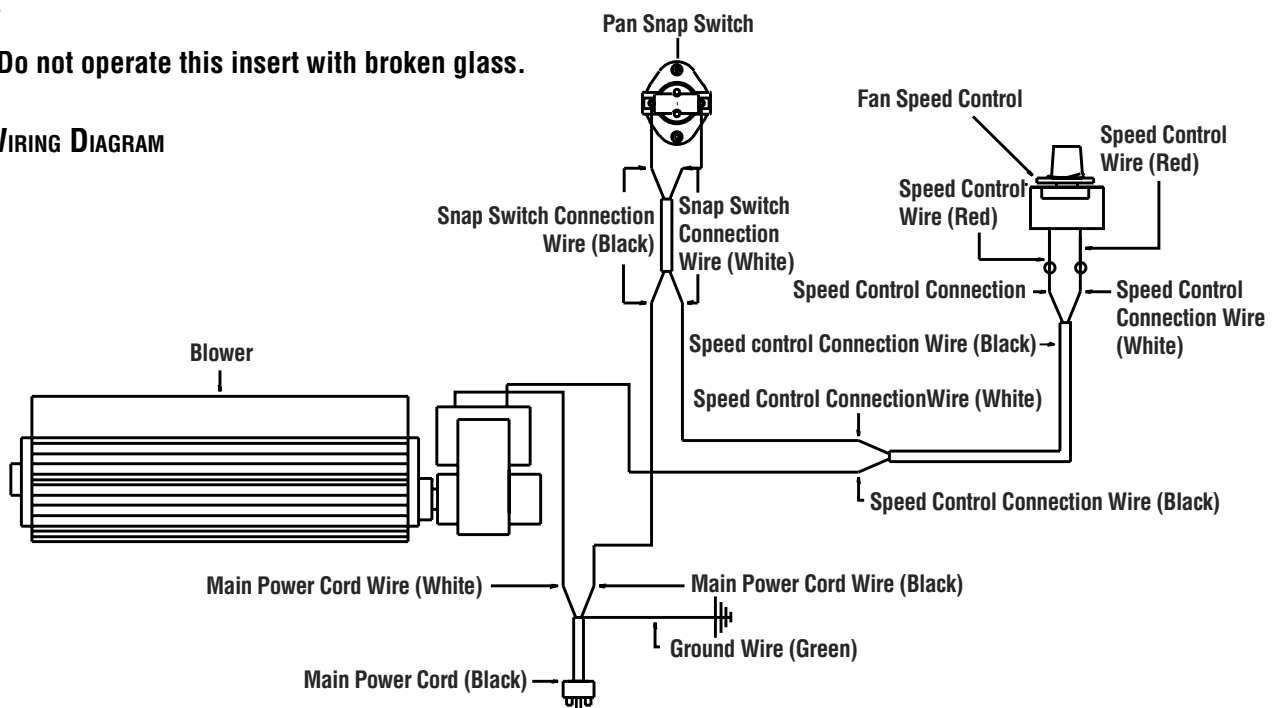

BLOWER REMOVAL

Unplug the power supply cord from the electrical outlet prior to removing the blower. The fan can be accessed through the back wall of the firebox. **Caution: Label all wires prior to disconnection when servicing controls. Wiring errors can cause improper and dangerous operation. Verify proper operation after servicing.** See the fan-wiring diagram below for reference. Remove the glass door, log set, and brick panels. All of these items are fragile so handle them with care. Remove the two allen-head screws at the left and right front of the air control panel and lift the panel out. Next, remove the nine allen-head screws around the outside of the panel fastened to the back wall of the firebox. Rotate the top of this panel toward the front, remove the two wires connected to the fan, and then lift the panel with the fan attached out of the firebox. To reinstall the fan, repeat these steps in the reverse order.

ELECTRICAL REQUIREMENTS

This gas insert operates without an outside power source, however the fan/blower requires a 120 Volt electrical service outlet. The blower must be electrically grounded in accordance with local codes. In the absence of local grounding codes, the National Electrical Code ANSI/ NFPA 70 - latest edition. The blower is equipped with a three pronged (grounding) plug for your protection against electrical shock hazard and should only be plugged into a properly grounded three prong receptacle. **DO NOT CUT OR REMOVE THE GROUNDING PRONG FROM THE PLUG FOR ANY REASON!**

- See Millivolt Control Schematic (Figure 19) for information on thermostat and On/ Off switch.
- See Blower Wiring Diagram (Figure 21) for information on the wiring and electrical requirements for the blower.

FUEL CONVERSION & CASSETTE INSTALLATION

Converting your FireStar™ gas insert between natural gas and LP can be accomplished by either changing the Quick Change Cassette (valve and pilot assembly) or installing a conversion kit (regulator, burner orifice and pilot orifice). Only a qualified service technician should perform the conversion, as it requires disconnecting the gas supply line and other procedures that should only be performed by a qualified technician.

Cassette Removal

1. Be sure the gas supply is off and fan power cord is disconnected before beginning the conversion. Disconnect the gas supply from the insert being careful not to apply pressure to the valve in the process.
2. Remove the log set and brick panels, (see “Brick Panel & Log Installation)
3. Remove the burner by lifting the left end and pulling the burner gently through the block plate and past the pilot assembly.
4. Disconnect at the valve the two wire connectors from vent safety snap switch (the uppermost black wire on terminal 1 and the black wire with the round connector located at the top of the valve and behind the gas inlet elbow). Then disconnect the thermostat (red and white wires) and rocker switch (black wires) at terminals #1 & 3.
5. Remove the socket head screw attaching the cassette/body block plate and block plate located in the bottom right end of the firebox.
6. Remove the socket head screw fastening the pilot end of the cassette to the burner holder.
7. Remove the three socket head screws holding the cassette (valve/pilot assembly) to the body of the insert.
8. The cassette can now be removed by rotating the valve forward and out to the right.
9. Install new, converted or serviced cassette in the reverse order of removal. All parts and wires must be correctly reinstalled to ensure safe and proper operation of the unit.

CONVERSION KIT

Please see instructions provided with conversion kit.

Troubleshooting

NOTE: When troubleshooting the gas control system, be sure the external gas shut off valve, located at the gas supply inlet is in the “ON” position.

IMPORTANT: Call your gas supplier or plumber for additional help with any gas control problem. Valve system troubleshooting should only be accomplished by a qualified service technician.

SYMPTOM	PROBABLE CAUSE	CORRECTIVE ACTION
Thin black coating (soot) forms on the viewing glass, logs, or firebox	<ol style="list-style-type: none"> 1) Improper log or ember placement 2) Improper air shutter setting 3) Not enough combustion air 4) Incorrect gas pressure 	<ol style="list-style-type: none"> 1) See Log Set Installation on Pages 9 & 10. If there is soot in one specific location, the rockwool below this location needs to be adjusted. This can be done by pulling embers forward slightly. If the flames have soot tails, the shutter will need to be opened. 2) If sooting continues open air shutter (see Air Shutter Adjustment on Page 12) 3) Check for debris obstructing air flow in valve compartment under insert or in front of lower venting. 4) Have gas supplier check for correct gas pressure (7" W.C. natural gas; 11" W.C. propane gas)
Humming or whistling coming from insert.	<ol style="list-style-type: none"> 1) Normal operating noise 2) Obstructed orifice opening 3) Defective regulator 	<ol style="list-style-type: none"> 1) See Quiet Operation on Page 15. The noise may be reduced by slightly turning down the flame. Turning the flame down will reduce the heat output of the insert. 2) If noise is excessive or is “whistling” have your gas supplier check the regulator and orifices and replace if necessary. 3) If noise is excessive or is “whistling” have your gas supplier check the regulator and orifices and replace if necessary.
A change in flame appearance or burner operation.	<ol style="list-style-type: none"> 1) A change in gas pressure 2) Improper ember placement 	<ol style="list-style-type: none"> 1) Have your gas supplier check for correct gas pressure (7" W.C. / po. C.E. [1.74 kPa] natural gas; 11" W.C. / po. C.E. [2.74 kPa] LP gas). NOTE: NEVER BLOCK OR OBSTRUCT AIR INTAKE OR OUTLET VENTS. 2) See Log Set Installation Instructions.
Spark igniter will not light pilot after repeated tries.	<ol style="list-style-type: none"> 1) No gas supplied to unit or air in line 2) Defective igniter (no spark at electrode) 3) Defective or misaligned electrode at pilot (spark at electrode) 	<ol style="list-style-type: none"> 1) Check gas supply. To purge, hold in gas cock on valve for 1-2 minutes and try again. 2) Check for spark at electrode and pilot, if no spark and electrode wire is properly connected, replace igniter and igniter wire. 3) Using a match, light pilot. If pilot lights, turn off pilot and trigger the igniter again. If pilot lights, an intermittent gas/air supply may be the problem, if longer purge will not light - check gap between electrode and pilot - should be 1/8 inch (3 mm) to have a strong spark. If OK, replace pilot.
Pilot will not stay lit after carefully following lighting instructions.	<ol style="list-style-type: none"> 1) Vent Safety Snap Switch shut down. 2) Improper Flame impingement 3) Low gas inlet pressure 4) Defective thermopile 5) Bad connection 6) Defective automatic valve operator 	<ol style="list-style-type: none"> 1) Snap switch activated, have venting system inspected for blockage, down draft or bad snap switch. 2) Check pilot flame adjustment (see "Maintenance" section). 3) Check inlet pressure and adjust pilot if necessary. 4) Be sure wire connections from thermopile are tight at gas valve terminals and at vent safety snap switch. 5a) Either rocker switch or thermostat wires may be grounded. Remove wires from valve terminals. If pilot stays lit, trace switch wiring for a ground. May be grounded to insert or gas supply. 5b) Check open circuit millivolt output of thermopile. Reading should be greater than 325mV. Also check thermopile wire for kinks that can cause loss of mV. Replace faulty thermopile if wire is okay and reading is less than 325mV. 6) Turn valve knob to “ON” and thermostat (if installed) to 90°. Millivolt meter should read greater than 100 mV. If reading is OK and burner does not turn on, replace gas valve (qualified service technician only).
Pilot burning, but no flame on main burner with valve knob “ON”, rocker switch and thermostat “ON”.	<ol style="list-style-type: none"> 1) Pilot has gone out 2) Rocker switch, thermostat, or wires defective 3) Thermopile may not be generating sufficient millivolts 4) Plugged burner orifice. 	<ol style="list-style-type: none"> 1) See Lighting Instructions. 2) Disconnect rocker switch and thermostat wires at terminals 1 and 3 on valve. Jumper across from 1 to 3 with pilot lit. If burner comes on either rocker switch, thermostat, or wiring is not functioning. If not, jumper wires across switch wires at gas valve. If burner comes on, wires are faulty or connections are bad. 3) Check thermopile with millivolt meter (see Maintenance and Servicing), recheck symptom #2. 4) Check burner for stoppage and remove.

REPLACEMENT PARTS LIST

PART #	DESCRIPTION
H5952	#33 NG Main Burner Orifice
H5953	#35 NG High Elevation Main Burner Orifice
H5951	#50 LP High Elevation Main Burner Orifice
H5843	2" Bottom Trim Piece
H5950	#49 LP Main Burner Orifice
H5860	4 Piece Log Set
H5844	Air Control Burner Pan
H5842	Baffle Plate
H5519	Baffle Plate Holder Brackets
75145	Black Door w/Glass
H5874	Blower Power Cord
H5877	Blower Speed Control
H5996	Blower Speed Control And Housing (Includes 2 Rivets)
H5997	Blower w/Mounting Bracket
H5866	Brick Panel Set
H5934	Burner Tube
H5740	Cassette Assembly NG (For LP Installations, Also Order LP Conversion Kit)
H5863	Volcanic Stone
H5985	Decorative Gold Bar On Lower Stove Body
H5986	Decorative Nickel Bar On Lower Stove Body
H5905	Door Rope (Per Foot) Order 8 Ft. for each door
75146	Gold Door w/Glass
H5875	Heat Sensed Blower Snap Switch
H3106	Left-hand Side Door (Mounting Brackets & Blower Speed Control Installed)
H5881	LP Pilot Assembly (Includes Thermopile, Electrode And Wire)
H5930	LP Pilot Orifice
H5940	LP Regulator
H5744	Main Burner On/Off Rocker Switch
H5995	Main Burner On/Off Switch Wires
H5981	Main Door Decorative Gold Bars Each (2 Per Stove)
H5982	Main Door Decorative Nickel Bars Each (2 Per Stove)
H6000	Middle Bay Glass W/glass Tape Installed
H5880	NG Pilot Assembly (Includes Thermopile, Electrode And Wire)
H5949	NG Pilot Orifice
H5939	NG Regulator
75147	Nickel Door W/glass
H5745	Piezo Igniter
H5999	Rheostat Wire
H5954	Robertshaw Main Gas Control Valve LP
H5937	Robertshaw Main Gas Control Valve NG
H5864	Rock Wool (embers)
H3107	Side Bay Glass W/glass Tape Installed Each (2 Per Stove)
H5998	Snap Switch Wire
H5882	Thermopile
75254	Top Trivet
H5993	Vent Safety Snap Switch W/bracket
H5994	Vent Safety Snap Switch Wires

Safety / Listing Label

MODEL **FIRESTAR INSERT/GC3** SERIAL NO.

Tested & Listed By **OTL** Beaverton Oregon USA
 OMNI-Test Laboratories, Inc.

LENNOX
 HEARTH PRODUCTS

Manufactured by:
 LENNOX HEARTH PRODUCTS
 PO BOX 987
 AUBURN, WA 98071 USA

FACTORY EQUIPPED FOR:
 NATURAL GAS
 PROPANE GAS

Report No. 050-S-07-5

IF CONTROL PANEL CONTRADICTS THIS LABEL, UNIT FUEL TYPE HAS BEEN CONVERTED.

VENTED GAS FIREPLACE HEATER - FIREPLACE INSERT - NOT FOR USE WITH SOLID FUEL

TESTED TO ANSI Z21.88-1998 "VENTED GAS FIREPLACE HEATERS".
 THIS APPLIANCE MUST BE INSTALLED IN ACCORDANCE WITH LOCAL CODES, IF ANY. IF NOT, FOLLOW THE CURRENT ANSI Z223.1 IN THE USA. THIS APPLIANCE MUST BE INSTALLED IN ACCORDANCE WITH THE MANUFACTURER'S INSTALLATION INSTRUCTION. FOR INSTALLATION IN SOLID FUEL BURNING FIREPLACES ONLY - MASONRY OR FACTORY BUILT.
 THIS VENTED GAS FIREPLACE HEATER IS NOT FOR USE WITH AIR FILTERS.
 THIS APPLIANCE NEEDS FRESH AIR FOR SAFE OPERATION AND MUST BE INSTALLED SO THERE ARE PROVISIONS FOR ADEQUATE COMBUSTION AND VENTILATION AIR.

RATINGS	NATURAL GAS	LP GAS
MAXIMUM INPUT BTUH 0-2,000 FT (0-610 M)	39,000	39,000
MINIMUM INPUT BTUH 0-2,000 FT (0-610 M)	27,000	22,600
ORIFICE (DMS) 0-2000 FT (0-610 M)	#33	#49
MANIFOLD PRESSURE (IN. WC)	3.5	10.2
MIN. INLET PRESSURE (IN. WC)	5.0	10.5
UNIT FACTORY EQUIPPED FOR 0-2000 FT/0-610 M		
ELECTRICAL RATING: 115 VAC, 60 HZ, LESS THAN 2 AMPS		

DANGER: RISK OF ELECTRICAL SHOCK. DISCONNECT POWER BEFORE SERVICING UNIT.
 IF ELECTRICALLY CONNECTED, CONNECTIONS AND GROUNDING MUST BE IN ACCORDANCE WITH LOCAL CODES, IF ANY. IF NOT, FOLLOW THE CURRENT NATIONAL ELECTRICAL CODE ANSI/NFPA 70.
 CHIMNEY - USE WITH B-VENT CHIMNEY OR LISTED SINGLE WALL GAS VENT FLEX CHIMNEY LINER.
 FOR ALTITUDES ABOVE 2,000 FT. (610 M) DE-RATE THE APPLIANCE BY FOUR (4)% FOR EVERY 1,000 FT (405 M).
 WARNING: OPERATION OF THIS APPLIANCE WHEN NOT CONNECTED TO A PROPERLY INSTALLED AND MAINTAINED VENTING SYSTEM OR TAMPERING WITH THE BLOCKED VENT SHUTOFF SYSTEM CAN RESULT IN CARBON MONOXIDE (CO) POISONING AND POSSIBLE DEATH.

MINIMUM FIREPLACE SIZES REQUIRED

- 29.75" Front Opening
- 19.00" Opening Height
- 19.00" Rear Width
- 15.25" Fireplace Depth

INSERT HEARTH PROTECTION - Non-Combustible Hearth Extension

H = Vertical Distance from Insert Bottom* to Combustible Material	0"	2"	4"	6"
G = Minimum Hearth Protection Distance from Fireplace Facing	23"	20"	17"	0"

* Insert bottom is the metal lip below the lower gold trim bar.
 Note: Hearth protection to be min. 3/8" thick non-combustible or equivalent.

CLEARANCES TO COMBUSTIBLES

- A = 14.5" to Top Facing (max thickness 3/4")
- B = 24" to Mantle** (more than 3/4")
- C = 6.5" to Side Facing (3/4" or less)
- D = 11" to Side Wall

** The minimum distance from the top of the insert to a combustibile may be reduced to 16" with a mantel shield. See owner's manual for shield dimensions.

MINIMUM CLEARANCES

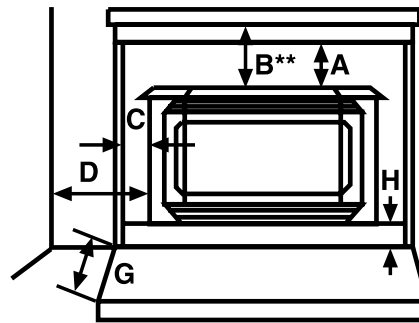

CAUTION: HOT WHILE IN OPERATION. DO NOT TOUCH. KEEP CHILDREN, CLOTHING, FURNITURE, GASOLINE AND OTHER LIQUIDS HAVING FLAMMABLE VAPORS AWAY. KEEP BURNER AND CONTROL COMPARTMENT CLEAN. SEE INSTALLATION AND OPERATING INSTRUCTIONS ACCOMPANYING APPLIANCE. DO NOT OPERATE THE APPLIANCE WITH GLASS REMOVED, CRACKED OR BROKEN. REPLACEMENT OF THE PANEL(S) SHOULD BE DONE BY A LICENSED OR QUALIFIED PERSON.

WARNING: IMPROPER INSTALLATION, ADJUSTMENT, ALTERATION, SERVICE OR MAINTENANCE CAN CAUSE INJURY OR PROPERTY DAMAGE. REFER TO THE OWNER'S INFORMATION MANUAL PROVIDED WITH THIS APPLIANCE. FOR ASSISTANCE OR ADDITIONAL INFORMATION CONSULT A QUALIFIED INSTALLER, SERVICE AGENCY OR GAS SUPPLIER.

DATE OF MANUFACTURE

2007 2008 2009 2010 JAN FEB MAR APR MAY JUN JUL AUG SEP OCT NOV DEC

FOR YOUR SAFETY READ BEFORE OPERATING

WARNING: IF YOU DO NOT FOLLOW THESE INSTRUCTIONS EXACTLY, A FIRE OR EXPLOSION MAY RESULT CAUSING PROPERTY DAMAGE, INJURY OR LOSS OF LIFE.

CAUTION: HOT WHILE IN OPERATION. DO NOT TOUCH. KEEP CHILDREN, FURNITURE, GASOLINE AND OTHER LIQUIDS WITH FLAMMABLE VAPORS AWAY. NEVER OPERATE UNIT WITH GLASS DOOR OFF OR ATTEMPT TO OPEN THE DOOR WHILE HOT.

- A. This appliance is equipped with a piezo ignition device to light the pilot. When lighting the pilot, follow these instructions exactly.
- B. **BEFORE LIGHTING**, smell around the appliance area for gas. Be sure to smell next to the floor because some gas is heavier than air and will settle on the floor.



WHAT TO DO IF YOU SMELL GAS:

- DO NOT try to light the appliance.
 - DO NOT touch any electric switch; do not use any phone in the building.
 - Immediately call your gas supplier from a neighbor's phone. Follow the gas supplier's instructions.
 - If you cannot reach your gas supplier, call the fire department.
- C. Use only your hand to push in or turn the gas control knob. Never use any tool. If the knob will not push in or turn by hand, don't try to repair it, call a qualified service technician. Force or attempted repair may result in a fire or explosion.
 - D. DO NOT use this appliance if any part has been under water. Immediately call a qualified service technician to inspect the appliance and to replace any part of the control system and any gas control which has been under water.

OPERATING INSTRUCTIONS

CAUTION: YOUR COUNTRY GAS STOVE MUST ALWAYS BE OPERATED WITH GLASS DOOR IN PLACE.

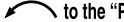
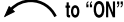
STOP! Read the safety information above before proceeding.

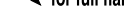
1. Open the right side door. Make sure gas supply shut-off cocks are open and ON/OFF Rocker Switch is "OFF".
2. Turn off all electrical power to the appliance.
3. Push in Gas Cock Dial slightly and turn clockwise  to "OFF".
NOTE: Dial cannot be turned from "PILOT" to "OFF" unless Dial is pushed in slightly. Do not force.
4. Wait five (5) minutes to clear out any gas. If you smell gas, STOP! Follow "B" above. If you don't smell gas continue.
5. Locate the pilot by looking through the notch in the bottom right end of the front log. Blue flame will be seen when the pilot is lit.
6. Turn the gas control knob counterclockwise  to the "PILOT" position.
7. Push the knob all the way in and hold in that position. Immediately light the pilot by pressing the ignitor button several times until pilot is lit. Continue to hold the knob in for about 30 seconds after the pilot is lit. Release knob and it will pop back out. Pilot should remain lit. If it goes out, repeat steps 4-8 holding knob in an additional 15 seconds after pilot is lit.
 - If knob does not pop out when released, stop and immediately call your service technician or gas supplier.
 - If the pilot will not stay lit after several tries, turn the gas control knob to "OFF" and call your service technician or your gas supplier.
8. After pilot is lit, turn gas control counterclockwise  to "ON". Knob can only be turned "ON" if the knob has popped out.
9. To turn burner on, turn "ON/OFF" rocker switch to "ON" or set the thermostat to the desired temperature above room temperature.
10. Adjust the flame height (and heat output) by turning the flame height knob clockwise  for full flame and counterclockwise  for reduced flame.
11. Set the blower to the desired air flow after it turns on when the appliance reaches operating temperature.

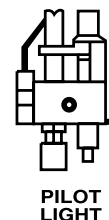
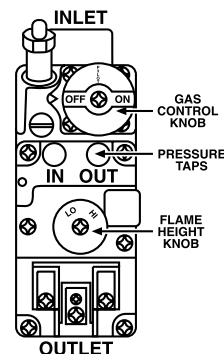

TO TURN OFF GAS TO APPLIANCE

1. Turn off the "ON/OFF" rocker switch and/or thermostat (if installed).
2. Turn off electric power to the appliance if service is to be performed.
3. Turn gas control knob clockwise  to "OFF". Do not force.

This appliance needs fresh air for safe operation and must be installed so there are provisions for adequate combustion and ventilation air. See Installation and Operation Manual accompanying appliance.

WARNING: Improper installation, adjustment, alteration, service or maintenance can cause injury or property damage. For assistance or additional information, consult a qualified installer, service agency or your gas supplier.

Operation of this appliance when not connected to a properly installed and maintained venting system or tampering with the vent safety shut off system can result in carbon monoxide (CO) poisoning and possible death.

SHUTDOWN PROCEDURE

1. To turn off the burner, switch the rocker switch to "OFF" or adjust the thermostat to a setting below room temperature (if installed). The pilot will remain lit for future burner ignition.
For complete shutdown: See "TO TURN OFF GAS TO APPLIANCE" above.

WARRANTY

Your gas appliance is covered by a limited warranty (provided with appliance). Please read the warranty to be familiar with its coverage.

Retain this manual. File it with your other documents for future reference.

PRODUCT REFERENCE INFORMATION

We recommend that you record the following important information about your fireplace. Please contact your Lennox Hearth Products dealer for any questions or concerns. For the number of your nearest Lennox Hearth Products dealer, please call 1-800-9-Lennox.

REPLACEMENT PARTS

See **Page 21** for a complete replacement parts list. Use only parts supplied from the manufacturer.

Normally, all parts should be ordered through your Lennox Hearth Products distributor or dealer. Parts will be shipped at prevailing prices at time of order.

When ordering repair parts, always give the following information:

1. The model number of the appliance.
2. The serial number of the appliance.
3. The part number.
4. The description of the part.
5. The quantity required.
6. The installation date of the appliance.

If you encounter any problems or have any questions concerning the installation or application of this system, please contact your dealer.

LENNOX HEARTH PRODUCTS

1110 West Taft Avenue

Orange, CA 92865

Visit us at www.Lennox.com

Your Fireplace Insert's Model Number _____

Your Fireplace Insert's Serial Number _____

The Date On Which Your Fireplace Insert Was Installed _____

The Type of Gas Your Fireplace Insert Uses _____

Your Dealer's Name _____

Fuel Type (Check one) Natural Gas Propane Gas (LP)

NATIONAL
FIREPLACE
INSTITUTE



CERTIFIED
www.nficertified.org

We recommend that our gas hearth products be installed and serviced by professionals who are certified in the U.S. by the National Fireplace Institute® (NFI) as NFI Gas Specialists.

Lennox™ reserves the right to make changes at any time, without notice, in design, materials, specifications, prices and also to discontinue colors, styles and products. Consult your local distributor for fireplace code information.

LENNOXTM

HEARTH PRODUCTS

1110 West Taft Avenue • Orange, CA 92865